

Ice Cream Bike with Standard 240V Mains Freezer

www.cargobike.co.uk
info@cargobike.co.uk
01332 49 26 59



Trike dimensions:

Length = 1950mm

Width = 870mm

Height = 1150mm

All dimensions in mm

All print areas are Width x Height

UK Manufacturer of high-quality ice cream trikes, promo cart and disabled cycles.

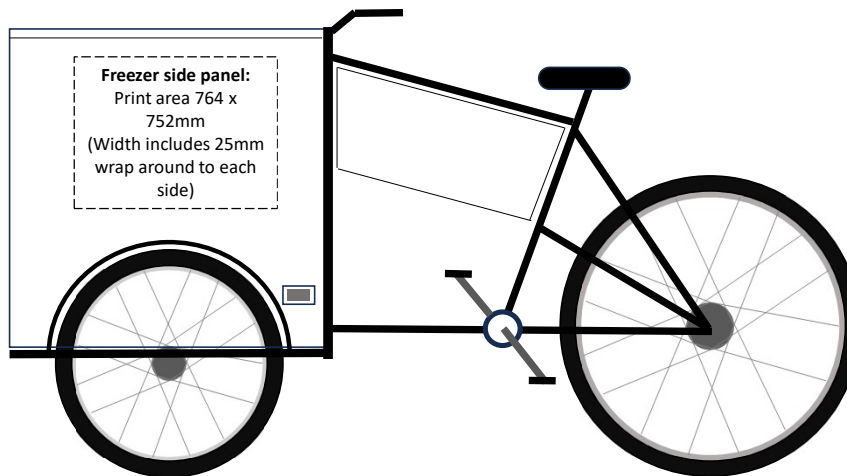
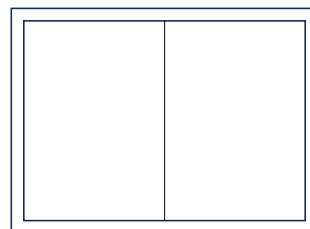

Frame panel

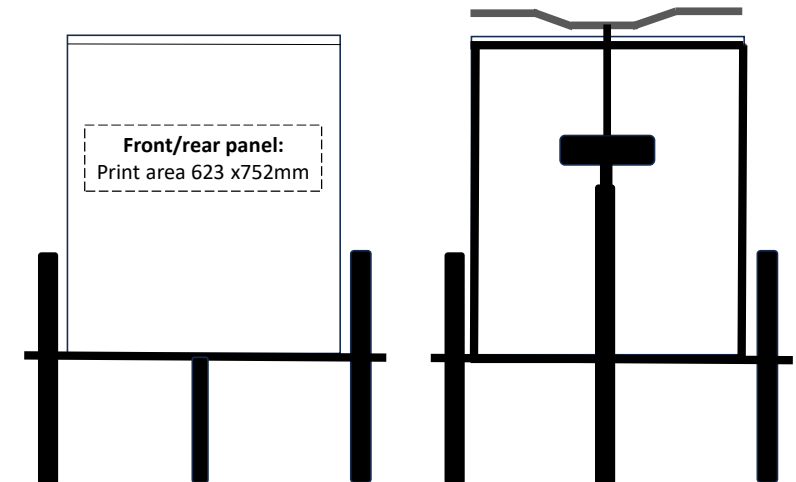
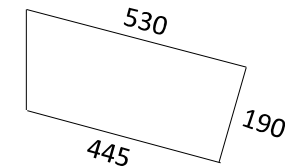

Ice Cream Bike with Standard 240V Mains Freezer and Storage Unit

www.cargobike.co.uk
info@cargobike.co.uk
01332 49 26 59



UK Manufacturer of high-quality ice cream trikes, promo cart and disabled cycles.

Trike dimensions:

Length = 2350mm
Width = 870mm
Height = 1150mm

All dimensions in mm

All print areas are Width x Height

**Storage unit top panel-
Wooden top or
branded**

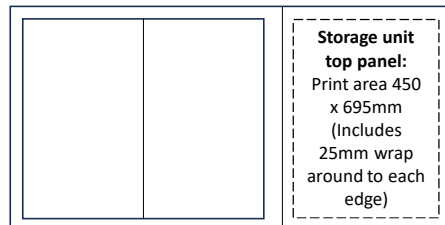

Frame panel

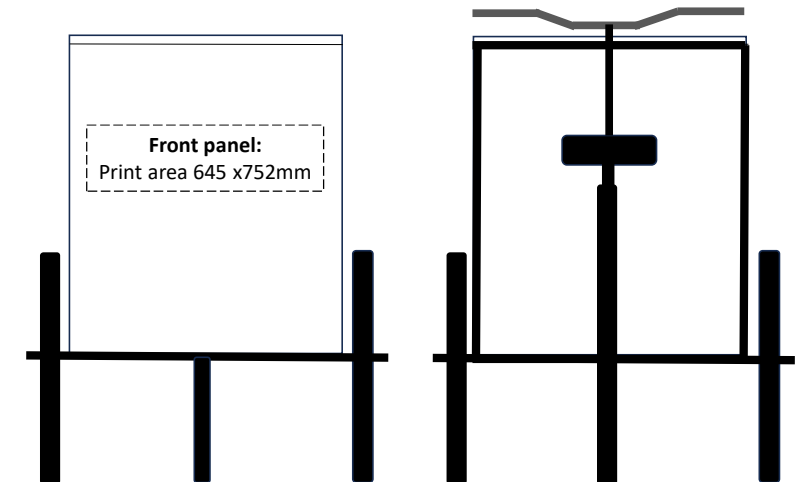
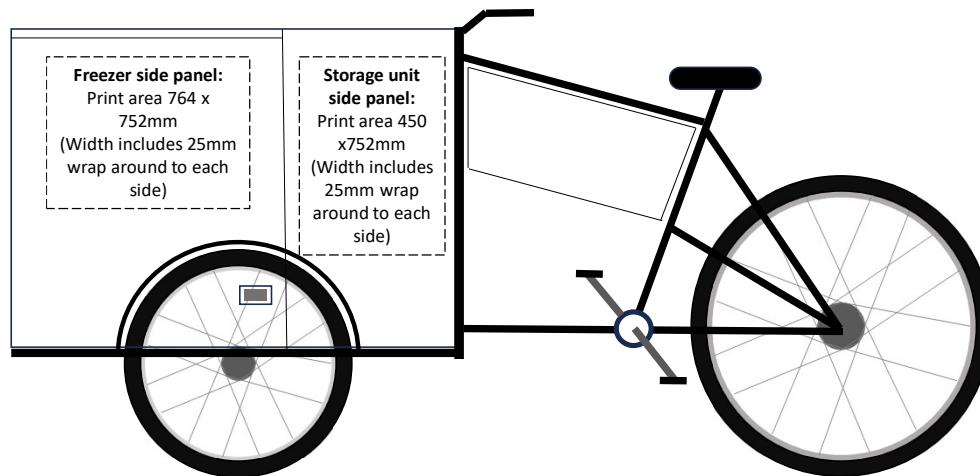
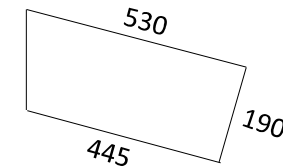

Ice Cream Bike with 12 volt Battery Freezer

www.cargobike.co.uk
info@cargobike.co.uk
01332 49 26 59



Trike dimensions:

Length = 1950mm
Width = 890mm
Height = 1150mm

All dimensions in mm
All print areas are Width x Height

UK Manufacturer of high-quality ice cream trikes, promo cart and disabled cycles.

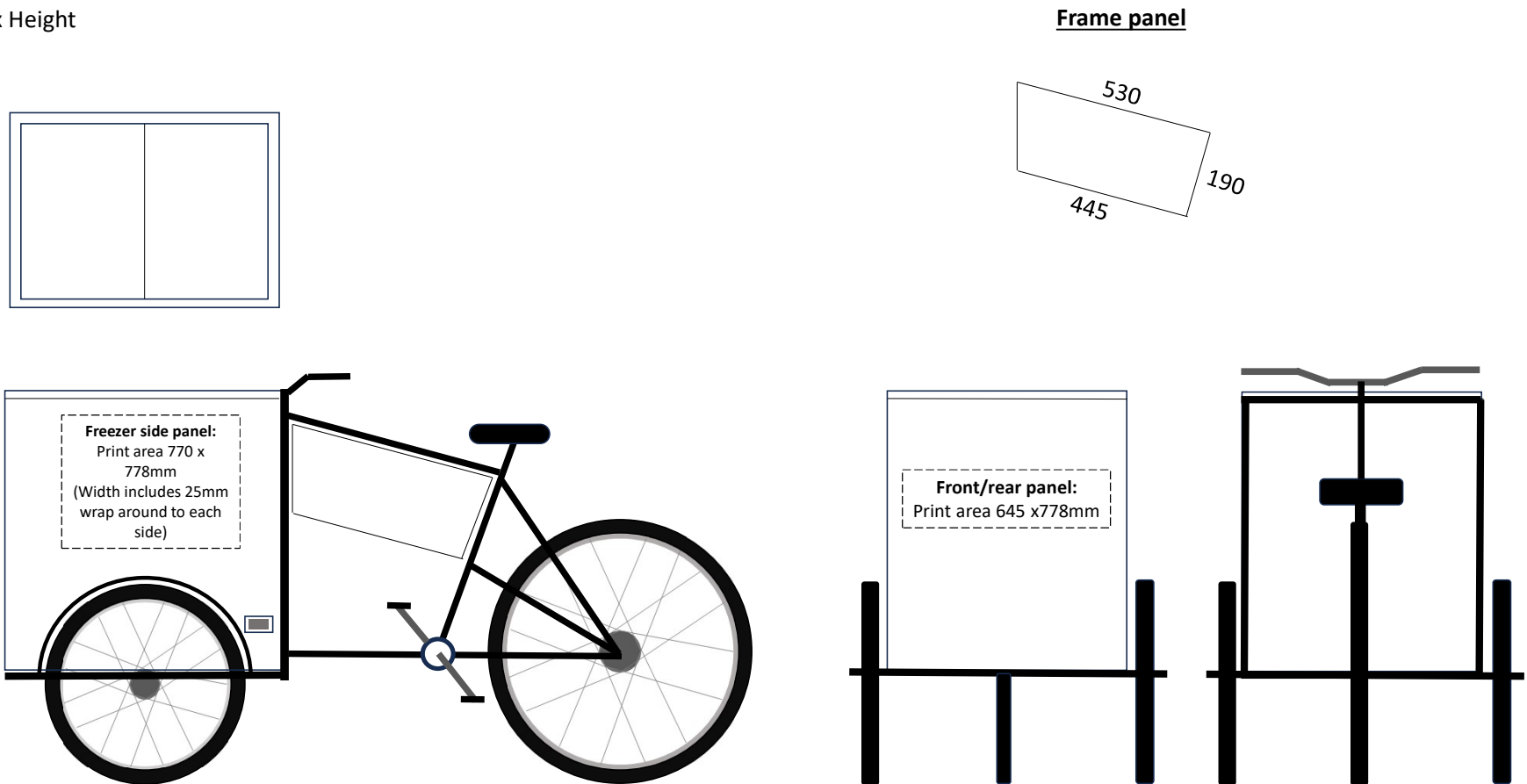

All graphics to be submitted as Press ready Adobe PDF / 30mm bleed with no crop marks / All fonts saved as outlines / All images embedded / One file per panel

Ice Cream Bike with Battery Freezer and Storage Unit

www.cargobike.co.uk
info@cargobike.co.uk
01332 49 26 59



UK Manufacturer of high-quality ice cream trikes, promo cart and disabled cycles.

Trike dimensions:

Length = 2350mm

Width = 890mm

Height = 1150mm

All dimensions in mm

All print areas are Width x Height

**Storage unit top panel-
Wooden top or
branded**

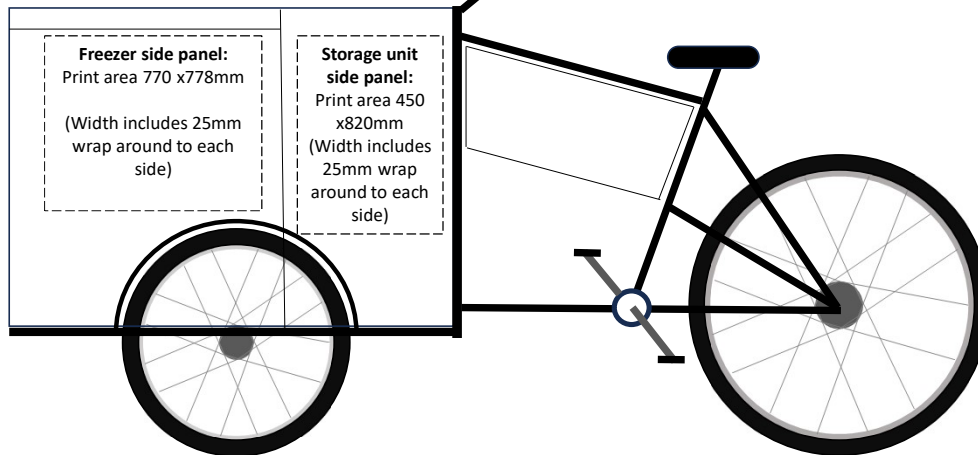
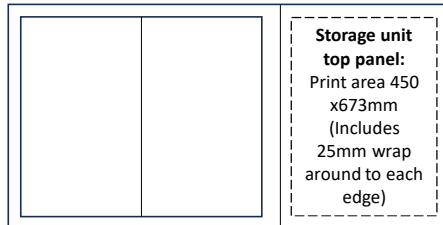

Frame panel

